

Addressable Controller

- Can connect to one or two compatible light strips of any length
- Various mounting options available
- Operating voltage: 10-30Vdc
- Preset and custom settings available for programming
- Drive Current: 2.1amps, 17.5 Watts max power
- UV compliant to ASTM G155
- Salt Spray compliant to ASTM B117
- Operating Temperature: -13° Fahrenheit to 113° Fahrenheit
- Suitable for all markets

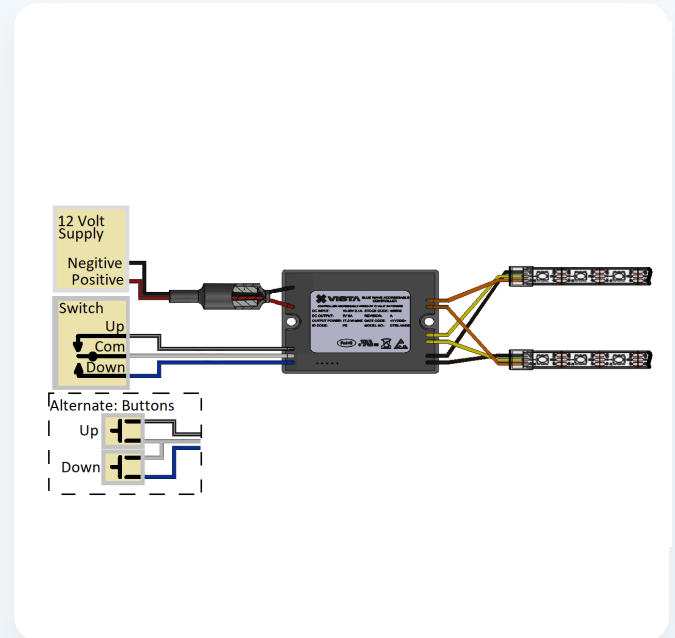

DIMENSIONS

TOP VIEW

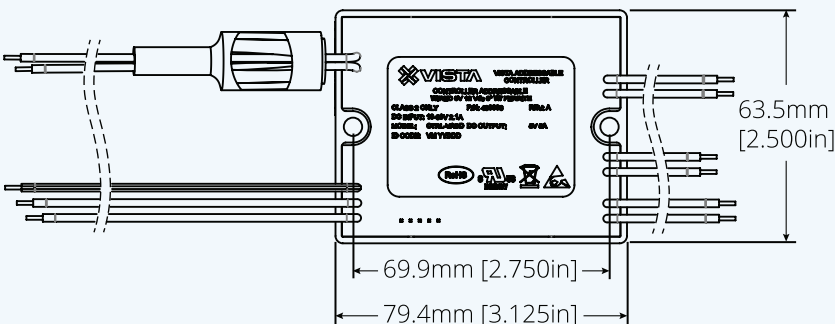

SIDE VIEW

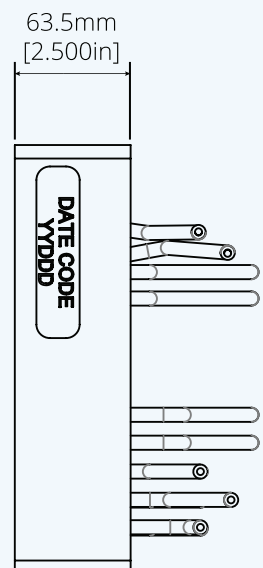

INSTALLATION INSTRUCTIONS FOR ADDRESSABLE CONTROLLER

MOUNTING: Choose the mounting location. When choosing mounting location keep the following in mind:

- Choose a location to minimize the possibility of being bumped into and a location away from excessive heat sources.
- Plan the routing of the wires to the power source, light strip(s), and control switch.

The Vista Addressable Module can be mounted using the recommended hardware listed in the chart below, depending on the material it is mounted to.

MATERIAL MOUNTED TO	RECOMMENDED FASTENER
Wood	#6 wood screw, round or pan head
Aluminum	#6 sheet metal screw, (optional self-tapping, self-drilling) OR #6 machine screw with mating nut
Fiberglass	#6 machine screw with mating nut and washer

WIRING: The Vista Addressable Module requires two to three different types of wiring connections. The wire connections can be made using solder and heat shrink, insulation-displacement connectors, wire nuts, or crimp splices. For most applications additional wire will be required between the devices being connected. When adding additional wire, ensure the wire meets the minimum wire gage mentioned for each type of connection below.

The Vista Addressable Module is powered from a 12-volt DC source. For automotive and marine applications, it can be connected to a 12-volt circuit that is protected by a 10-amp fuse. For building applications, a class 2, 12-volt power supply must be used. See power supply instructions for its mounting and connection to the building mains. The Vista Addressable Module's red wire connects to the supply's positive terminal and the black wire connects to the supply's negative terminal. Use AWG 18 or larger for these connections.

The Vista Addressable Module can be connected to one or two compatible addressable light strips using the sets of black, orange, and yellow wires. The two strips will display the same light sequence and should be the same length. Either one of the black wires connects to the light strip's negative supply input. Either one of the orange wires connects to the light strip's 5-volt supply input. Either one of the yellow wires connects to the light strip's data input. Use AWG 18 or larger for these connections. If only one light strip is connected, insulate the unused black, orange, and yellow wires with heat shrink, electrical tape, or other insulators.

The Vista Addressable Module must be connected to a control switch that will allow the user to select the preprogrammed light sequences. A single-pole, double-throw, center-off, momentary switch is recommended. Alternately, two momentary pushbuttons can be used. Use AWG 18 or larger for these connections.

For a double-throw switch, connect the white wire to the switch's common terminal. Connect the black / white wire to the switch contact relating to the up, or forward, contact. Connect the blue wire to the switch contact relating to the down, or reverse, contact.

For momentary pushbuttons, connect the white wire to one contact on each button. Connect the black / white wire to the remaining contact on the up, or forward, button. Connect the blue wire to the remaining contact on the down, or reverse, button.

————— *Vista reserves the right to modify this specification without prior notice.* —————

SET UP: Light Strip Length Detection and Programming:

The Addressable Controller can be connected to light strips of any length. Some of the preprogrammed light sequences require the controller to know the length of the light strip to function properly. The Addressable Controller has a learning mode to detect the length of the attached strip and program it into the Controller. The following procedure should be performed when the controller is installed or any time the strip length is changed.

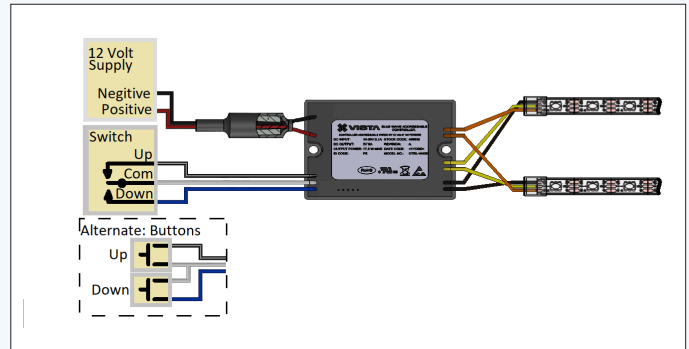
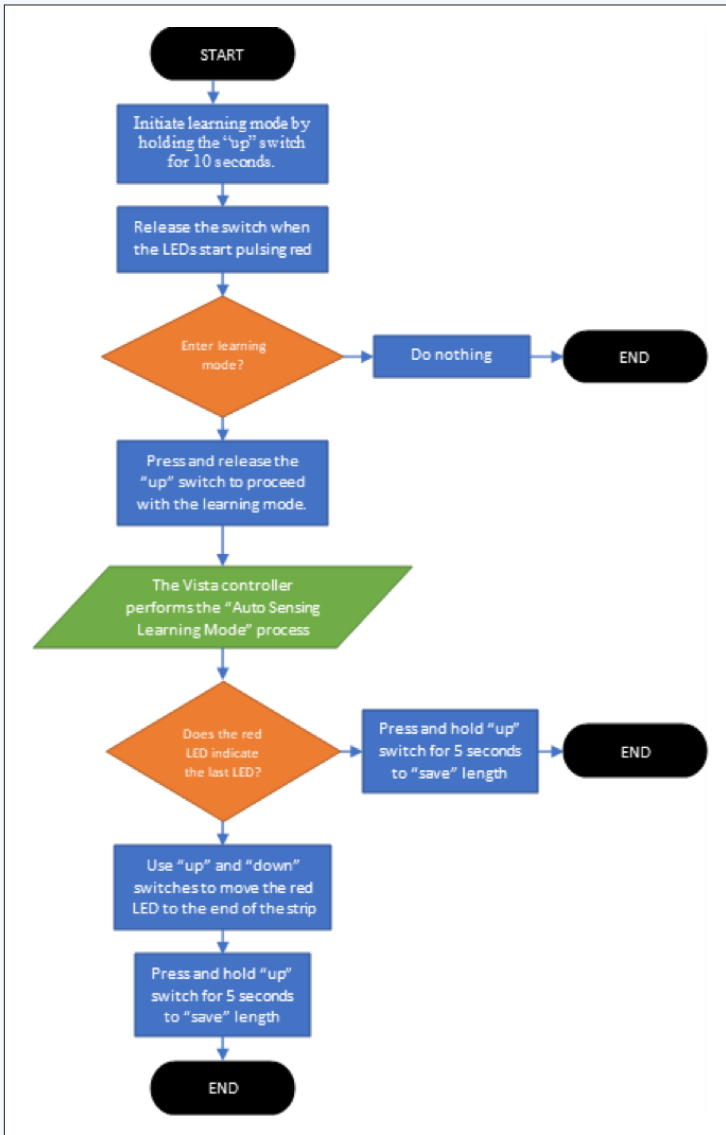

OPERATION: The use of the switch inputs requires the connection of a user supplied switch or buttons as shown in the Wiring section of these instructions. When the switch is properly connected, the user can cycle through the predefined light sequences listed below. Each press and release of the "UP" or "FORWARD" switch advances to the next light sequence. Each press and release of the "DOWN" or "REVERSE" switch selects the previous light sequence.

Selectable Light Sequences:

0 – OFF

1 – One Color Fade: All LEDs in strip change at the same time fading from one color to the next

2 – Eraser: Traveling White bar (eraser) on solid color background. At the start of the sequence, the white bar moves down the strip, and the current color of the LEDs change to another color. The white bar returns to the beginning once falling off the end, and each time, the color of the strip changes to another color as the white bar passes over them.

Vista reserves the right to modify this specification without prior notice.

3 – Multi Color Chase: Six LEDs are on, and they change colors while traveling down the strip. The sequence cycles back to beginning after falling off the end of the strip.

4 – RGB Tail Chase: Red, Green, and Blue tails chase, one after the other, with space in between down the strip and cycle back to the beginning after falling off the end.

5 – Rainbow: Also known as circus, cycles through multiple colors, chasing back toward the beginning of the strip, all LEDs on the strip powered on and cycle continuously.

6 – Opposite Rings: A white tail starts at one end, and a blue tail starts at the other end. Once each tail reaches the opposite end of the strip, they bounce back the other direction and switch colors when they bounce off the ends of the strip.

7 – Two-tone Chase: Four blue with three red LEDs chase down the strip and cycle back to the beginning after falling off the end.

SPECIFICATIONS:

Electrical:

Input Power:

Operating Voltage: 12 VDC

Supply Current: 2.1 A max

Power: 25 W max

Output:

Output Voltage: 5 VDC

Output Current: 5 A max

Output Power: 25 W max

Environmental:

Operating Temperature: -20 to 45 °C

IP Rating: IP65

Dimensions:

Height: 17.02 mm (0.670 in)

Width: 57.74 mm (2.273 in)

Length: 79.38 mm (3.125 in)

Length of wires: 152.40 mm to 139.7 mm (6 in to 5.5 in)

WARRANTY STATEMENT:

GENERAL LIMITED WARRANTY: Vista warrants, to the original customer, that all LED products will be free of defect in material and/or workmanship for a period of two years from the original date of purchase. This warranty will be voided if the product is damaged or rendered inoperable by accident or incident, improper installation, unreasonable or improper use, vandalism, user modification or alteration, negligence, abuse, lack of maintenance, unauthorized repair, disassembly, improper handling, applied voltage or other changes unrelated to materials and/or workmanship.

MAXIMUM LIABILITY: Vista's liability to repair or replace a damaged item shall be limited to original purchaser of the item at the original purchase price of the damaged unit for two years from date of purchase. All liability of Vista shall be limited to and fully discharged by repair or replacement of such defective items without charge. In no event, whatsoever shall Vista be liable for incidental or consequential damages, including without limitation, removal or reinstallation costs, personal injury or property damages. Vista's liability shall not exceed Vista's invoiced price for the product on any claim arising from its use.

INSPECTION: Vista reserves the right to review the damaged item and the site where the damage occurred. Vista may require the purchaser to ship the items to Vista for inspection and the cost of such shipping shall be borne solely by the purchaser. The damaged item must remain available for inspection until the claim is finalized.

EVENTS THAT VOID WARRANTY: All above warranties are null and void if any or more of the following event occur;(a) the item is not provided to Vista for inspection upon Vista's request; (b) Vista determines that the item has been improperly installed, altered in any way or tampered with; and/or (c) Vista determines that the item was not used under normal operating conditions or in accordance with label or instructions for the item. In addition to the foregoing, this Warranty does not protect against damage to the item when Vista determines, in its sole discretion, that the damage resulted from acts of God such as lightning, flood, earthquake, war, vandalism, theft, normal-use wear and tear, corrosion, abuse, non-authorized program or system equipment modification or alteration.

Vista reserves the right to modify this specification without prior notice.

EXCLUSIVE REMEDY: This Warranty contains the sole warranty of Vista with respect to the item and is given in lieu of all other warranties. There are no other warranties, express or implied, including implied warranties or merchantability or fitness for a purpose and any implied warranties that cannot be waived and/or excluded are hereby limited in duration to the terms of this Warranty.

CREDIT OR REPLACEMENT PARTS: Credit or replacement will not be issued for materials returned without a Returns Good Authorization (RGA). Simply call Vista at our corporate office at (574) 264-0711 with an itemized list of goods, reason for return, and quantities to be returned. Once an RGA number has been issued to you, simply return the product, to Vista at the address given. Once the goods have been evaluated by our quality personnel, a credit will be issued, or replacement parts will be shipped. Credit will be issued for products only, no freight or labor will be credited, unless agreed to in advance. Replacement parts will be sent at no charge, freight prepaid. Vista reserves the right to choose any of these options at its discretion.

DAMAGED GOODS: If you received damaged product from UPS or Common Carrier, please do not return product to Vista. Contact the shipper to initiate a claim. If you receive damaged goods through a Vista delivery, please contact your sales representative or Vista directly. Buyer understands and agrees that this purchase is subject to the limited Warranty attached hereto. Venue for any dispute arising or relating to this agreement shall lie exclusively in Elkhart County, Indiana.

Vista reserves the right to modify this specification without prior notice.
