

Vista Vivid

- Vibrant neon look created with LEDs in a white or red PVC tube
- No hot spots
- Comes in 8 vibrant colors
- Different mounting options available – shown below
- Designed for exterior and interior applications, IP66 rated
- Tips available for finished look
- Operating voltage: 11 – 14Vdc
- UL Listed / ROHS Compliant
- UV complaint to ASTM G154
- Salt Spray compliant to ASTM B117
- Available in lengths from 3-1/2" to 144"



SPECIFICATIONS

PART NUMBER	LED COLOR	WAVELENGTH (nm)/ CCT (KELVIN)	LUMINOUS FLUX/ft	AMPS/ft	MAX RUN LENGTH (ft)
461046	Warm White	3000K	345	0.26	18.5
462046	Red	622nm	71	0.26	18.5
463046	Amber	590nm	100	0.26	18.5
464046	Natural White	4500K	345	0.26	18.5
465046	Green	523nm	329	0.26	18.5
466046	Blue	465nm	95	0.26	18.5
467046	Purple	--	--	0.26	18.5
469046	Cool White	6000K	345	0.26	18.5

Vista Vivid

DIMENSIONS

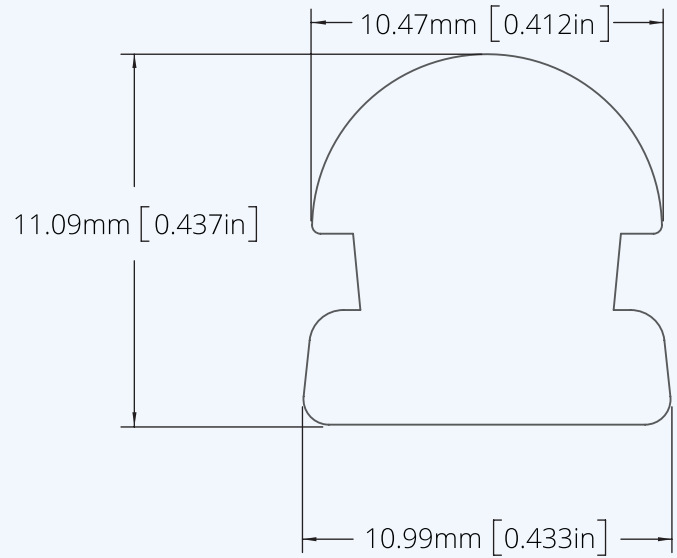
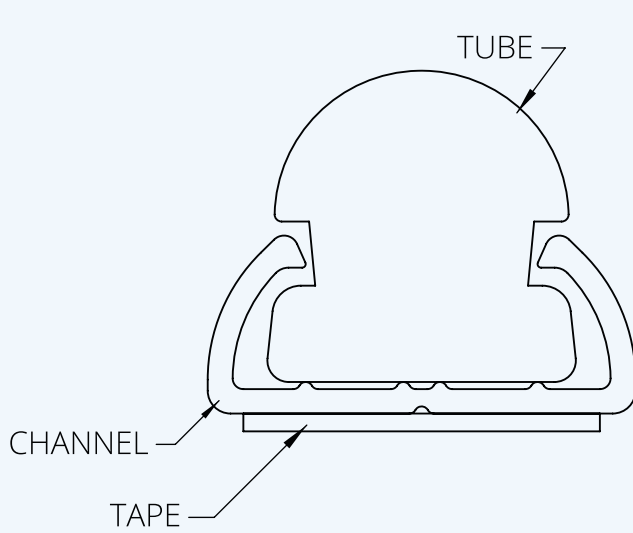

CLIP: AVAILABLE IN CLEAR OR BLACK

ALUMINUM CHANNEL: AVAILABLE IN CHROME OR BLACK FINISH

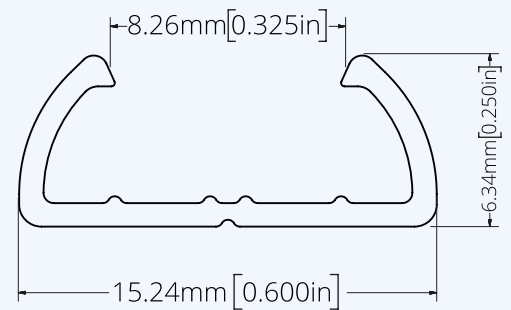
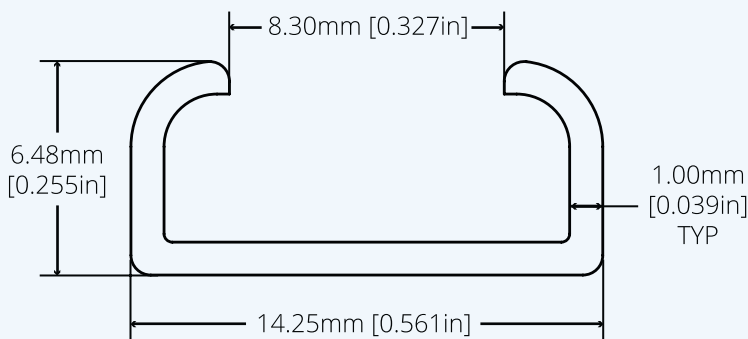

Vista reserves the right to modify this specification without prior notice.

TIP: AVAILABLE IN CHROME OR BLACK FINISH

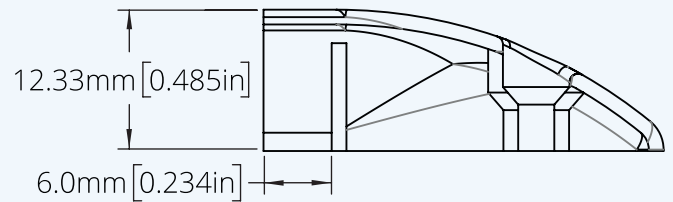
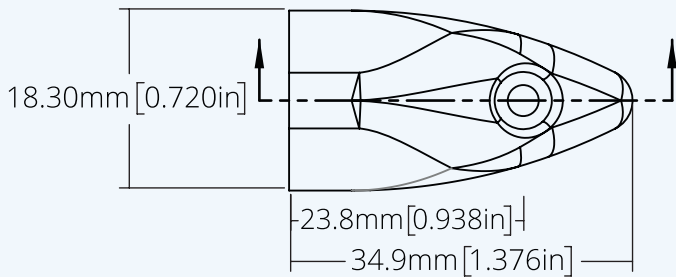

INSTALLATION INSTRUCTIONS

PRODUCT IDENTIFICATION: Determine the mount type of your linear light

Adhesive: Full length or intermittent adhesive attached to the bottom of the extrusion profile.

Clips: Short-length press in clips, mounted with fasteners, that allow routing of a light in a non-linear fashion.

Channel: Full length rigid or semi-rigid channel, mounted with fasteners, available with adhesive backing for temporary hold. Some channel products come with finishing tips which contain a fastener location or predrilled support holes inside of the channel for fasteners. Other channels must be pre-drilled prior to fastening to the mount surface.

PREPARATION: Prepare the mount surface in accordance with your fastener type

Adhesive: It is recommended to use an adhesive promoter in order to increase the bond strength for all types of adhesive tape (adhesive promoter not included). If an adhesive promoter is not available, prep the mount surface with isopropyl alcohol to increase bond strength. Make sure that while mounting flexible lights, a bend radius smaller than the minimum bend radius of your selected product is not applied. Mounting flexible lights beyond the minimum bend radius will void warranty.

Clips: When setting up clip locations for lights in a non-linear fashion, make sure that the clip locations will not produce a bend radius smaller than the minimum bend radius of your selected product. Mounting flexible lights beyond the minimum bend radius will void warranty.

Channel: If the channel has an adhesive backing follow the preparation instructions for adhesives above. If the channel has finishing tips, make sure that the full assembly will fit in the intended mounting location. Channels should be mounted on a flat surface to ensure that light extrusions will remain secure. If holes are not already pre-drilled into the channel, locate and drill the mounting holes now. It is recommended to have a mount hole at least every 9".

FASTENING: Using product appropriate fasteners, mount the light to your desired surface. It is up to the installer to ensure the proper fasteners are used for the application mount surface. Mechanical fasteners supplied by Vista are generic fasteners. If these are not appropriate for the intended mount surface, a customer supplied fastener should be identified and used.

Adhesive only: After preparation, peel away the adhesive backer. It is recommended for long, non-linear applications, that the adhesive backer is removed in sections so that the light can be routed without accidental adhesion. After initial adhesion, apply pressure evenly throughout the adhered surface for at least 30 seconds. All adhesive mounted products should be allowed 24 hours of cure time before being acted upon by an outside force to ensure best adhesion.

Clips: Pre-drill clips (if not already done) and locate them along the mount surface, keeping in mind not to exceed the minimum bend radius of the selected product. After clips are located and mounted, route the light extrusion through the clips by pressing until the fastening mechanism of the clip is engaged.

Channel: Remove the light extrusion from the channel if already assembled. If the channel selected has adhesive, determine the required mounting position of the light and peel away the adhesive backer. Apply the channel to the mount location and apply

Vista reserves the right to modify this specification without prior notice.

pressure evenly throughout the adhered surface for at least 30 seconds. This is intended to be a temporary adhesion. Apply fasteners into the pre-drilled holes inside of the channel for permanent fixturing. The holes located nearest each end of the channel are meant for wire routing and finishing tips see Figure 1. Do not apply fasteners to these holes. Drill a hole through the mounting surface in the proper location for wire routing if necessary. Make sure that if there are finishing tips and the wires are routed straight out of the end of the extrusion, the wire routing hole will not interfere with the screw mounting of the finishing tip. Press or slide the light extrusion into the channel, Apply finishing tips to channel (if applicable) routing wires through if necessary.

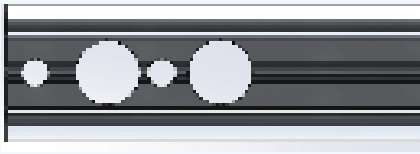

Figure 1
Wire routing and finishing tip holes
Do not apply fasteners

WIRING: Route wires as necessary for the application. Do not pinch or puncture wires with fasteners. Do not route wires around sharp edges. A wire loom should be used for protection if wires are to be routed through areas where they may encounter sharp edges, in an application that would experience high amounts of vibration, in areas that may have fasteners protruding into them during later assembly, or other extreme conditions. Standard wiring outputs can be seen below.

INCANDESCENT LIGHTS: Do not have a defined power and ground



Brown Wire



White Wire



Red/Black Wire

SINGLE COLOR LIGHTS



Black Wire (Ground)
Red Wire (Power)

RGB LIGHTS (RED, GREEN, BLUE) When red, green, and blue LEDs are all on, a “white” light is produced.



Black Wire (Power)
Blue Wire (Blue Ground)
Green Wire (Green Ground)
Red Wire (Red Ground)

RGBW LIGHTS (RED, GREEN, BLUE, WHITE) Red, green, blue, and white LEDs



Black Wire (Power)
White Wire (White Ground)
Blue Wire (Blue Ground)
Green Wire (Green Ground)
Red Wire (Red Ground)



DISCONNECT POWER SOURCE (BATTERY) BEFORE STARTING ELECTRICAL WORK.

Recommended methods for splicing wires together (parts not included in Vista product kits):

- Solder, add heat shrink or electrical tape to cover the bare wires.
- Insulation-displacement connector (IDC) / insulation-piercing contact (IPC).
- Twist on wire connector, “wire nut”.
- Crimp connector, “Butt splice”

Vista reserves the right to modify this specification without prior notice.